

The Concentration of Isotopes by the Evaporative Centrifuge Method

J. W. BEAMS AND C. SKARSTROM

Rouss Physical Laboratory, University of Virginia, Charlottesville, Virginia

(Received May 31, 1939)

The air-driven vacuum-type tubular centrifuge has been used for the concentration of the isotopes of chlorine by the "evaporative" centrifuge method. The separations obtained were about the same as predicted by the theory provided the experimental conditions approximately conformed to the assumptions of the theory. With a steel tube 11" long and 3" inside diameter, containing baffles to prevent remixing, and spinning at 1060 r.p.s., carbon tetrachloride vapor could be withdrawn from the axis at the rate of 3.2 grams per minute without decreasing the separation factor. This separation factor for chlorine, which at any instant is the ratio of the concentrations of the light to heavy isotopes at the axis, divided by the same ratio at the periphery, was 1.025 in the above case. It is believed that the method is practical in the case of the heavier elements.

ALTHOUGH the general theory for the separation of isotopes by centrifuging has not been completely worked out, the theory for the separation obtained in an ideal gas and in an incompressible liquid after equilibrium is established was given by Lindemann and Aston in 1919.^{1, 2} Since that time it has been further discussed and extended, especially by Mulliken,³ Chapman⁴ and Harkins,⁵ and several attempts have been made to obtain a separation experimentally.^{3, 6, 7} In every case the experiments proved to be unsuccessful and the method was generally considered as impractical. However, the high rotational speed, as well as the convection-free sedimentation, attained by the self-balancing vacuum-type ultracentrifuge^{8, 9} has encouraged us to give the method another trial. This seemed worth while because, according to the theory, the separation factor should depend principally upon the differences in the masses of the isotopes rather than their absolute values so that, if successful, the method could separate the isotopes of the heavier elements as well as the lighter. The pre-

liminary results¹⁰⁻¹³ indicated that a separation in very rough accord with theory could be obtained provided the process was carried out slowly enough for equilibrium to be established. In the present paper a continuation of this work is described, in which the theory has been more accurately verified, and in which improvements in the experimental technique have greatly increased the rate of separation.

The general procedure principally used in this work is similar to the "evaporative centrifuge" method suggested by Mulliken.³ It consists in drawing out vapor from the axis of a hollow spinning rotor containing liquid near its periphery. If this process takes place slowly enough for an equilibrium to be established between sedimentation and diffusion, and if the vapor approximately obeys the ideal gas laws, then the separation factor

$$S = \exp \frac{(M_2 - M_1)\omega^2 r^2}{2RT} \quad (1)$$

for a mixture of two isotopes, where S is defined as the ratio of the concentrations of light to heavy isotopes at the axis divided by the same ratio at the periphery of the rotor. M_2 and M_1 are the atomic weights of the heavy and light

¹ F. A. Lindemann and F. W. Aston, *Phil. Mag.* (6) **37**, 523 (1919).

² F. W. Aston, *Mass Spectra and Isotopes* (Arnold, 1933).

³ R. S. Mulliken, *J. Am. Chem. Soc.* **44**, 1033 (1922); **44**, 1729 (1922); **45**, 1592 (1923).

⁴ S. Chapman, *Phil. Mag.* (6) **38**, 182 (1919); *Phil. Trans.* **A217**, 115 (1918).

⁵ W. D. Harkins, *J. Frank. Inst.* **194**, 783 (1922).

⁶ J. Joly and J. H. J. Poole, *Phil. Mag.* (6) **39**, 372 (1920).

⁷ J. H. J. Poole, *Phil. Mag.* (6) **41**, 818 (1921).

⁸ J. W. Beams and E. G. Pickels, *Rev. Sci. Inst.* **6**, 299 (1935).

⁹ J. W. Beams, *J. App. Phys.* **8**, 795 (1937); *Rev. Mod. Phys.* **10**, 245 (1938).

¹⁰ J. W. Beams and F. B. Haynes, *Phys. Rev.* **50**, 491(L) (1936).

¹¹ J. W. Beams and A. V. Masket, *Phys. Rev.* **51**, 384(A) (1937).

¹² Skarstrom, Carr and Beams, *Phys. Rev.* **55**, 591(A) (1939).

¹³ Somewhat similar results have been reported recently on the separation of bromine by R. F. Humphreys, *Phys. Rev.* **55**, 674(A) (1939).

isotopes, respectively. ω is the angular velocity of the centrifuge; r is the radial distance from the liquid surface to the axis; T the absolute temperature; and R the gas constant. The change in average atomic weight $\Delta\bar{A}$ of the element in the residue from that in the original material, according to Mulliken,³ is, for a mixture of two isotopes:

$$\Delta\bar{A} = \frac{(M_2 - M_1)^2 X_1 X_2 \omega^2 r^2}{2RT}$$

$\times \log_e C$ approximately, (2)

where X_1 and X_2 represent the mole fractions of the light and heavy isotopes in the material and C is the so-called cut which is the ratio of the volume of the material present initially to the volume of residue remaining in the centrifuge. Mulliken has further shown that the above formulas for the separation are independent of the state of combination of the element.

Since the separation to be expected should be the same for any compound of the element, it was decided to carry out the development work with carbon tetrachloride because of its availability, noninflammability, suitable vapor pressure at room temperature, and easy condensability at dry-ice temperature. Furthermore, the isotopic analysis was simplified because it is suitable for density measurements, and chlorine could be conveniently used in the mass spectrograph available. Since the concentration of C^{13} is small, there are five principal molecular species, namely $C^{12}(Cl^{35})_4$; $C^{12}(Cl^{35})_3Cl^{37}$; $C^{12}(Cl^{35})_2(Cl^{37})_2$; $C^{12}Cl^{35}(Cl^{37})_3$; and $C^{12}(Cl^{37})_4$. In ordinary CCl_4 , if each molecular species is built up from the atoms according to chance, then the concentrations of the various species are given by the terms of the binomial expansion of $(X_1 + X_2)^4$.

In some of the preliminary experiments a rotor having a hollow flat cylindrical chamber 8.9 cm diameter and 0.64 cm high was spun in a vacuum⁹⁻¹¹ at 1550 r.p.s. The CCl_4 vapor was drawn out of the center at the rate of 2 cc of liquid per hour. Under these conditions the observed separation was only about 40 percent of that to be expected from the equilibrium theory. If the rate of drawing out vapor was decreased, the separation was increased, so it was concluded that the rate of withdrawal of

vapor was too rapid for approximate equilibrium to be established without stirring. In order to correct this, an apparatus was developed for spinning long hollow tubes in a vacuum. Fig. 1 shows a vertical section of the apparatus. The rotating members consist of the tubular centrifuge C which spins inside the vacuum chamber V , an air-supported air-driven turbine T situated above V , and the flexible shafts A and L which lie in their vertical axis of rotation. The shaft A

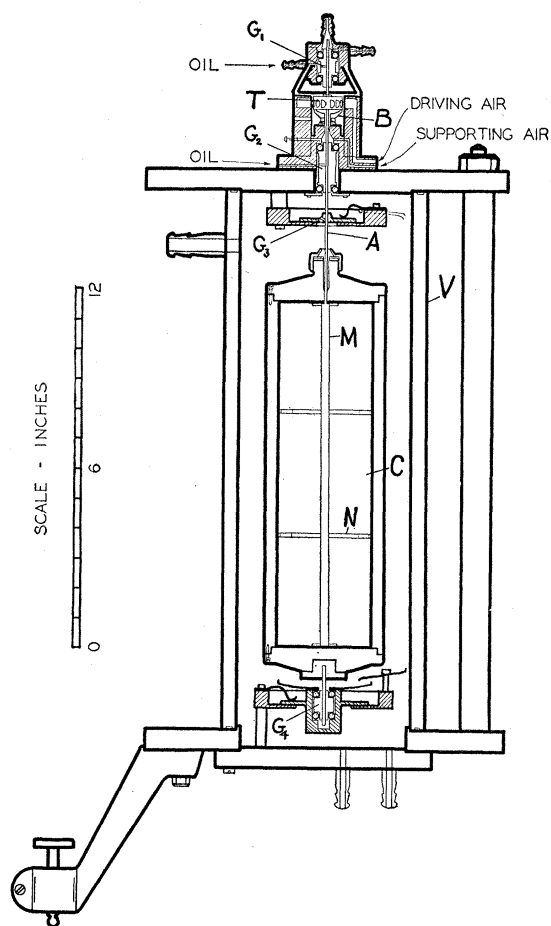

FIG. 1. Schematic vertical section of the centrifuge.

is a hollow stainless steel tube (hypodermic needle tubing gauge 14). It passes through the vacuum tight oil glands G_1 and G_2 , which have been described in detail previously.⁹ The shaft A was fastened to the air turbine by a chuck and to the tubular rotor C by a pinchuck which both clamps the shaft and imbeds itself into a lead

gasket, forming a vacuum-tight seal. Consequently the tubular rotor can be evacuated through the hollow shaft *A*. The pillbox-shaped Duralumin turbine *T* (1" diameter $\times \frac{3}{8}$ ") is supported by an air cushion formed between its undersurface and the Bakelite collar *B*. This air cushion supports all of the rotating members, which weigh about 25 lb. If this free air space directly beneath the turbine is made small and care is taken to make sure that the rubber or Duprene ring upon which *B* rests is uniformly flexible, rotors weighing at least 75 lb. can be supported. The turbine is driven by air jets impinging upon flutings milled into its periphery.¹⁴ The auxiliary bearings *G*₃ and *G*₄ inside the vacuum chamber were added to reduce precessional motions, especially during the period of acceleration. Each of these bearings, which were made of hard babbitt, was mounted in a loose plate that was kept in contact with a fixed plate by leaf springs. This construction supplied sufficient radial friction to inhibit the precession. These bearings were supplied with oil by the drippings from the oil gland *G*₂, the lower one receiving the overflow from the upper. This vacuum pump oil is finally collected, filtered, and used over again. The tubular rotor *C* was made of chrome molybdenum steel alloy¹⁵ 11" long $\times 4$ " O.D. $\times \frac{1}{2}$ " wall, with a yield point of 159,000 lb./in.². This tube has already had 700 hours of rotation at from 1000 to 1100 r.p.s. On one occasion the speed was increased to 1200 r.p.s. At this speed the rotor stretched radially, causing the gaskets between the tube and the Duralumin ST14 end caps to leak. Upon examination the internal diameter of the rotor was found to have increased 0.02". The tube was boiled in water for 30 minutes and has since been in use 400 hours at about 1060 r.p.s. Care was taken to machine carefully both the inner and outer walls of the tube and to see that it was dynamically balanced. The small steel tube *M* is uniformly perforated with a large number of fine holes so

¹⁴ For a more detailed description of this type of driving and supporting mechanism, reference should be made to *J. App. Phys.* **8**, 795 (1937); *Rev. Mod. Phys.* **10**, 245 (1938); *Rev. Sci. Inst.* **9**, 413 (1938).

¹⁵ Obtained from the Summerill Tubing Company, Bridgeport, Pennsylvania. Recently we have used tubes from the same source of chrome molybdenum steel 4130 X SAE 24" long $\times 4$ " O.D. $\times \frac{1}{2}$ " wall, with tensile strength of 200,000 lb./in.².

that the vapor is drawn out at a uniform rate along the axis of the spinning tube. *N* are circular Duralumin ST14 disks perforated with holes, which served to brace the tube *M*. The vacuum chamber *V* consisted of an 18" length of cold-rolled steel tubing 7" O.D. $\times \frac{1}{2}$ " wall, which was closed at both ends by steel disks that had been lapped to fit. Vacuum wax was used to give a vacuum-tight seal. Three tie rods were used to bolt the chamber together. As a precaution

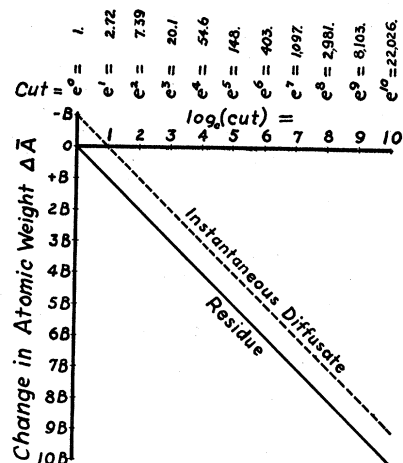

FIG. 2. Relation between the change in average atomic weight ΔA and $\log_e C$. For chlorine under the experimental conditions $B = \frac{(Cl^{37} - Cl^{35})^2 \omega^2 r^2}{2RT} X_1 X_2 = 9 \times 10^{-3}$ app. For CCl_4 the change in average molecular weight $\Delta M = 36 \times 10^{-3} \log C$.

against explosion, the apparatus was enclosed by a barricade consisting of a 10" thickness of soft wood. The vacuum chamber was evacuated through dry-ice traps by a mercury diffusion pump backed by a Cenco Hyvac pump.

To operate the machine 105 cc of CCl_4 were either injected into the rotor through *A* by a long small hypodermic needle or were distilled in while the rotor was running. The former method was usually used when the rotor was started from rest, and the latter when the material had to be put in with the rotor at full speed, i.e., when several different "batches" were centrifuged the same day. Since the pressure of the CCl_4 vapor at the center was only about one-seventh that at the periphery, the rotor acts as a pump and pulls the CCl_4 in very rapidly, especially when the air is removed from the system. The condensation

of the CCl_4 , of course, at first heats the rotor since it is in a vacuum, but is not enough to give serious trouble because of the rotor's size. Vacuum pump oil is forced into G_2 at a pressure about 15 lb./in.² greater than the supporting air pressure. The vacuum pump oil pressure in G_1 was about 10 lb./in.². The supporting air pressure could be varied over as much as 20 lb./in.² without causing instability in the air cushion, but it was usually set at 45 lb./in.². The driving pressure was set at 100 lb./in.² until the desired speed was attained, then reduced to the proper value to keep the centrifuge at constant speed. The speed was measured by beating the note given off by the turbine against a known frequency. The air pressure was held constant by a pressure regulator which, when properly set, kept the rotational speed sufficiently constant. The variations in the rotational speed were very slow because of the large moment of inertia of the rotor, so that the air valves could be adjusted manually. The total amount of air required to accelerate the centrifuge was 20 cu. ft./min. and to keep it at constant speed at 1060 r.p.s. was 11 cu.ft./min. each, reduced to standard conditions.

After reaching the desired speed the air was quickly pumped out of the rotor C . The CCl_4 vapor was allowed to flow out through A at the desired speed and was condensed in dry-ice traps in a number of successive fractions. The first fractions collected showed a concentration of the light isotope, while the last fractions and the residue showed a concentration of the heavy isotope. The changes in the isotopic ratio were determined by differential density measurements and by the mass spectrometer. In the density measurement considerable quantities of material were necessary and it was essential to purify it carefully. Baker's C. P. CCl_4 was distilled several times to remove as many impurities as possible before centrifuging. Since in the process of centrifuging the material might become contaminated by oil or other impurities in the machine, each fraction measured was again purified by shaking with P_2O_5 followed by several vacuum distillations until the density remained unchanged with further distillation. The CCl_4 was then placed in a special Pyrex glass pycnometer with long uniform capillaries closed with glass stoppers. This pycnometer was placed in

a temperature bath which was constant to at least 0.01°C as measured by a Beckmann thermometer. The heights of the menisci in the capillaries were determined by a cathetometer. Weighings were made on a chemical balance. The pycnometer held about 3.60 grams of CCl_4 and the density changes could be determined to 0.006 percent. The mass spectrometer was modeled after one described by Blewett.¹⁶ A change in the isotopic ratio of about two percent could be determined and only a few drops of the material were required. The mass-spectrometer determinations also are independent of possible impurities. The two methods were in good agreement in almost every determination.

In Fig. 2 the solid curve shows the change in the average atomic weight $\Delta\bar{A}$ of the residue remaining in the rotor as a function of the amount of residue, while the dashed curve shows the $\Delta\bar{A}$ in a very small amount of the material drawn off at any instant (instantaneous diffusate). The curves are computed from Mulliken's theory^{8, 5} assuming equilibrium is established when the vapor was drawn out slowly enough to insure that stirring was absent and equilibrium was approximately established. The experimental results obtained were in good accord with the curves. Because of the small changes obtained with small cuts, the measurements were carried out on samples which were residues with cuts from 6 to 330. The circles in

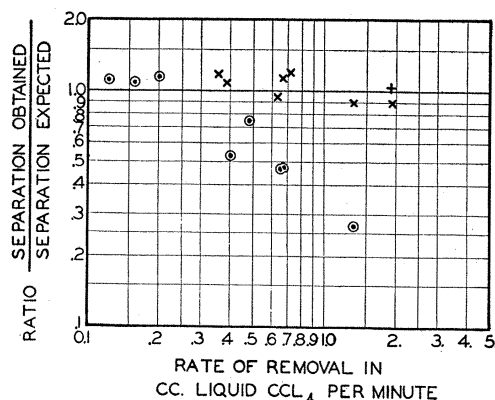

FIG. 3. The circles give the results obtained with the hollow tube shown in Fig. 1. The crosses give the results obtained with the "spider" baffles shown in Fig. 4.

¹⁶ J. P. Blewett, Phys. Rev. 49, 900 (1936).

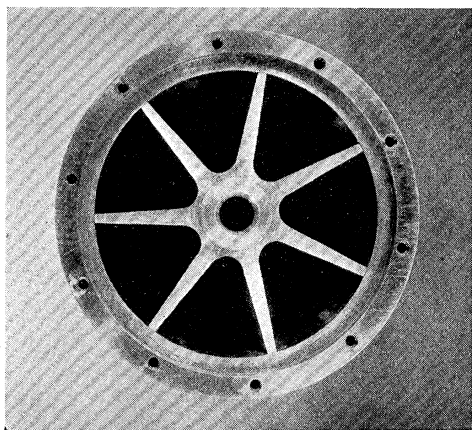

FIG. 4. Photograph of tubular rotor with end cap removed, showing the "spider" baffle in place. The vapor enters the axial channel through a large number of uniformly spaced small holes (not shown) connecting the sector-shaped compartments with the axial channel.

Fig. 3 give the ratio of the separation obtained experimentally, divided by the separation computed from the theory (Eq. (2)), plotted against the rate of removal of the material from the hollow tube of Fig. 1. It will be observed that when the rate of removal exceeds about $\frac{1}{5}$ cc/min., the efficiency of separation begins to fall off. In the absence of a complete theory of the separation, it was of course impossible to compute the time required for equilibrium to be established, although rough estimations indicated that it might be more rapid than indicated by the experiments. The possibility that the isotopic composition at the surface of the liquid was changed to an enrichment of the heavy isotope, which would cause the efficiency of separation to decrease at high withdrawal speeds, also could be ruled out. When the evaporation takes place from the liquid surface, it is cooled. This increases the density of the surface layer and causes violent stirring in the liquid⁹ so that it automatically is kept uniformly mixed during the centrifuging. The possibility of stirring in the vapor due to thermal gradients also was eliminated by theoretical calculations and experimentally by introducing hydrogen at a few mm pressure into the rotor to minimize temperature gradients. The introduction of the hydrogen produced no appreciable change. It was decided finally that

the decrease in efficiency was caused by stirring or remixing in the vapor. Since the angular momentum of the vapor is conserved as it moves from the liquid surface near the periphery toward the center, it rotates at a higher angular velocity than the centrifuge. This "whirlwind" apparently became large enough to stir or remix the vapor at withdrawal speeds above one-fifth of a cc per min. In order to reduce this type of stirring, a star-shaped spider made of Duralumin ST14 was introduced into the rotor, as shown in Fig. 4. This formed long sector-shaped cells for the diffusion to take place and should reduce circulation. With this arrangement it was found that no decrease in efficiency was observed with a rate of withdrawal of 2 cc of liquid CCl_4 per minute (represented by the crosses in Fig. 3), which was the highest rate we could obtain through the gauge 14 shaft *A* at room temperature.

The above experimental results show that the separation attained is roughly that predicted by the theory, provided equilibrium exists. Hence the assumption of the theory that the vapor obeys the ideal gas laws apparently does not introduce large errors.

In these experiments the value of the separation factor S was 1.025 for chlorine.* The value of $\Delta\bar{A}$, of course, changed as the isotopic ratio changes, since the mole fractions X_1 and X_2 change. Unfortunately, a tube is not a very strong mechanical construction for a centrifuge and the peripheral velocity was only about 2.5×10^4 cm/sec. In the smaller centrifuges we obtained a separation factor for carbon tetrachloride of 1.1 with a peripheral velocity of 5×10^4 cm/sec. However, the very high speed with which the vapor can be withdrawn from the long tubular rotor gives it a great advantage. Starting with 105 cc of CCl_4 in the tubular rotor, one obtains about 40 cc of liquid CCl_4 with the isotopic ratio changed by 2.5 percent in 32.5 min., or 14 cc of liquid CCl_4 with the isotopic ratio changed by five percent in 46 min., or 1 g

* The separation factor S for carbon would, of course, be 1.012, since the mass difference of the isotopes is one. Hence the carbon 13 is concentrated in the residue in the centrifuging of CCl_4 . One advantage of using compounds is that isotopes of all of the different elements in a compound are separated simultaneously.

with the ratio changed by 12.8 percent in 52.3 min. In addition to these, one also simultaneously collects a series of intermediate fractions with the enrichments given by the dashed curve in Fig. 2. By recentrifuging these intermediate fractions the rate of isotopic enrichment is much increased.

CONCLUSIONS

It will be observed from the above results that in order to get large changes in the isotopic ratio, very large "cuts" must be made. This means that one must start with large volumes of material and recentrifuge many times. The intermediate fractions must also be collected and recentrifuged. Such a procedure is rather slow and tedious unless several machines are available that may be run simultaneously. On the other hand, if large quantities of material are desired, with, say, 15 percent or 20 percent or less change in the isotopic ratio, the method in its present state is comparatively fast. Apparently, from experiment, equilibrium is established very quickly when stirring is eliminated by baffles, so that even in the case of compounds of the heaviest elements, it should be possible to pass the material through the machine rapidly. Since the separation factor depends only upon the differences in the masses, the results obtained with chlorine should be practically duplicated in any element whose isotopes have a mass difference of two. If they have a greater mass difference or spread, as in the case of many of the heavier elements, the separation factor is increased by this difference in the exponent of e . The evaporative centrifuge method can only be used for substances which may be liquefied at the periphery of the rotor which, at the same time, have a considerable vapor pressure. Fortunately this limitation is not as serious as might be thought at first, because many of the compounds of the elements (including the metal organic compounds) may be used. Furthermore, the vacuum-type centrifuges have been operated successfully in our laboratory with the rotor temperatures varying from 100°C to liquid-air temperatures. Incidentally, it should be noted that the absolute temperature enters into the equation for the separation factor in the denominator of the ex-

ponent of e . Consequently the separation increases with decreasing temperatures.

In the above experiments, when stirring was prevented by baffles, it was not possible to draw out the vapor fast enough to obtain a measurable decrease in separation due to absence of equilibrium. However, it is possible to more than double the diameter of the tubular shaft so that the rate at which equilibrium is established will undoubtedly set the final limit to the speed with which the material can be centrifuged.

The amount of material that can be passed through a single machine and still have equilibrium practically established should be proportional to the length of the tube. As yet we have found no upper limit to the length of tube that can be spun, and there is little doubt that tubes several feet long can be spun successfully. The equilibrium probably would be established faster in smaller diameter tubes. The separation factor can be increased considerably over the values obtained in the above experiments with somewhat stronger rotor material available. Even a small increase in rotor strength, and hence greater permissible peripheral velocity, should make possible considerable increase in the separation factor, since the peripheral velocity is squared in the exponent of e , Eq. (1).

For large concentrations of the isotopes in smaller quantities of material, it is probable that the evaporative centrifuge method is inferior to other possible centrifuge methods. The continuous-flow vacuum-type tubular centrifuge,¹⁷ which at present is being used, possesses several points of superiority over the evaporative method. Furthermore, Professor Urey has suggested to us that if an apparatus somewhat analogous to his fractionating columns could be mounted in a long tubular centrifuge in such a way that the separation would result from the effective diffusions of the material through the centrifugal field many times (i.e., the material would diffuse from periphery to center, then be thrown back out without diffusion. This process would take place over and over again), then the separation could be greatly increased. If such an arrangement proves to be feasible experimentally, it should be a relatively fast method of separation

¹⁷ J. W. Beams, *Rev. Sci. Inst.* **9**, 413 (1938).

—first, because of the large values for the separation factor; and second, because of the high speed with which equilibrium between diffusion and sedimentation is apparently established. It is hoped that a test of this method can soon be made.

The writers are greatly indebted to Mr. H. E. Carr, who did many of the mass-spectrometer measurements; to Messrs. Fritz Linke and Philipp Sommer, instrument makers, who constructed the centrifuges; and to the Research Corporation for a grant in support of the work.

AUGUST 1, 1939

PHYSICAL REVIEW

VOLUME 56

Regularities in the Third Spectrum of Thorium

R. J. LANG

Department of Physics, University of Alberta, Edmonton, Canada

(Received May 24, 1939)

The thorium spectrum is very rich in lines and extends into the far ultraviolet beyond 200A. The lines have been classified into II, III and IV as far as 1500A by means of the pole effect. A condensed spark in air and in nitrogen between metallic electrodes was used. The Th III spectrum lies on the short side of 3500A with most of its strong lines between 3000 and 2200A. Twenty-four energy levels are given.

A CONDENSED spark in air or nitrogen between electrodes of metallic thorium connected to a 30,000-volt transformer was employed to separate the lines of the thorium spectrum into the three spectra II, III and IV. In a previous report¹ the main lines of Th IV were classified into the usual single-electron doublet system with the very large 2P interval of 12,818 cm^{-1} . (See note at end.) These Th IV lines are scattered throughout the spectrum from 2694 to 847A and are easily distinguished by the pole effect, in the region down to 1500A where it can be applied, by the fact that while the lines are very intense they are completely broken, while Th II lines are not affected at all, or very slightly, and those of Th III are intermediate, i.e., they are markedly constricted but not entirely broken. Of course there are gradations in any one spectrum and in the region between 3500 and 3000A, where there is complete overlapping of II and III, it is not always possible to distinguish them. The most of the main lines of Th III appear to lie between 3000 and 2200A but it seems likely that some of the several thousand lines in the vacuum spark below 1000A will belong to this spectrum.

¹ R. J. Lang, *Can. J. Research* **A14**, 43 (1936).

There are many strong lines in the region between 600 and 400A.

Owing to the structure of the IV spectrum, in which the deepest term is a doublet D arising from a single (d) electron, it is to be expected that the III spectrum will have a structure similar to Zr III² and not to Ce III.³ The intervals of the (dp) terms are hopelessly irregular already in Zr III and the intensity rules in the $(ds)^3D - (dp)^3P^3D^3F$ multiplets in Zr III and Cb IV⁴ are so badly obeyed that sometimes the satellites have greater intensity than the main diagonal lines. Consequently an attempt was made to find intervals which might be suitable for the $(ds)^3D$ and the (deepest) $(d^2)^3F$ terms.

Table I shows twelve even and twelve odd energy values and the lines upon which these are based. Many of these lines are the strongest in the spectrum.

During the progress of this work two reports on thorium spectra appeared.^{5, 6} Through the

² C. C. Kiess and R. J. Lang, *Nat. Bur. Stand. J. Res.* **5**, 305 (1930).

³ H. N. Russell, R. B. King, and R. J. Lang, *Phys. Rev.* **52**, 456 (1937).

⁴ R. J. Lang, *Zeeman Verhandelingen* (Martinus Nijhoff, Hague, 1935), p. 44.

⁵ Mark Fred, *Astrophys. J.* **87**, 176 (1938).

⁶ T. L. de Bruin and J. N. Lier, *Proc. K. Akad. Amsterdam* **41**, 956 (1938).

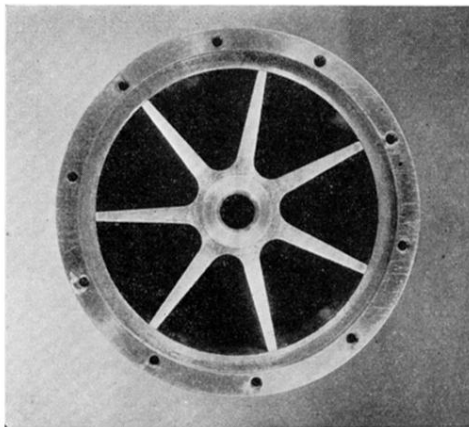

FIG. 4. Photograph of tubular rotor with end cap removed, showing the "spider" baffle in place. The vapor enters the axial channel through a large number of uniformly spaced small holes (not shown) connecting the sector-shaped compartments with the axial channel.